

# Kidde ECS Advanced Delivery Fire Suppression System Component Description

## Switch-In Gauge, Supervisory Pressure Switch for Nitrogen



Effective: October 2014

K-85-116

### FEATURES

- Factory Installed
- Integrated Pressure Switch and Gauge
- Compact Design
- Steel Braided Tether with Connector Included
- UL Listed, File Number 4674 for use with Kidde Fire Systems Nitrogen Pilot Cylinders, Siren Driver Cylinders and ADS Nitrogen Driver Cylinders

### DESCRIPTION

The Kidde ECS Advanced Delivery Fire Suppression System Switch-in-Gauge unit is a cylinder contents gauge and supervisory pressure switch integrated into a single package. The unit is factory installed and is supplied complete with a removable 4-conductor tether, which connects to a flexible junction on the back of the gauge body. The tether is protected by a stainless steel over-braid. The heat shrink sleeve is pre-installed on the finished end of the tether. A uniformed sleeve is also included for the connection to the system wiring.

Connected to an appropriate control panel, the unit initiates an alarm or fault condition when the pressure within the nitrogen cylinder is outside of the standard operating range.

### OPERATION

The Switch-In-Gauge contains a NO (Normally Open) switch that is CLOSED when the cylinder assembly is properly pressurized. When connected to a monitored circuit of a suppression control panel, with a correctly rated EOL (end of line) resistor, a deviation from normal operating pressure results in fault or alarm condition.

The Kidde ECS Advanced Delivery System Switch-in-Gauge unit is designed to trip when the pressure in the container drops to the level equivalent to the pressure at the lowest permissible operating temperature. The unit also provides a switch response when the container pressure exceeds the level equivalent to the pressure at the highest permissible operating temperature. In addition the unit will trip if power is lost (regardless of the container pressure).

**Note:** An indication of a fault is not necessarily an indication of a loss of pressure—all cylinder pressure readings must be corrected for temperature.

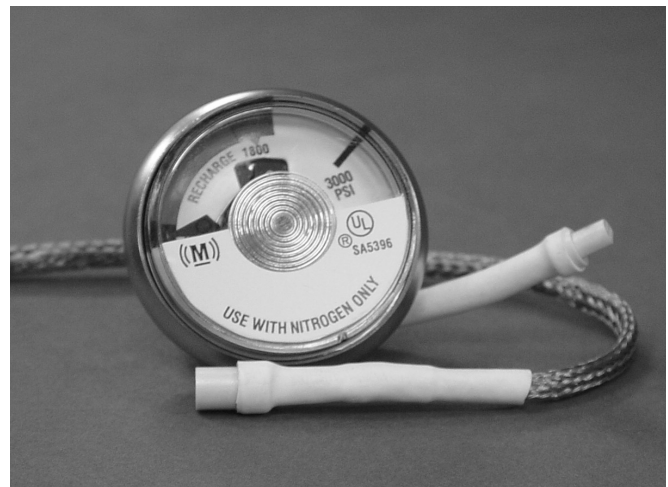

### INSTALLATION



**Kidde ECS Advanced Delivery System Switch-in-Gauge units (as with standard contents gauges) must not be removed or installed while a container is pressurized. Switch-in-Gauge units are factory installed only. Attempting to remove any container gauge from a pressurized container could result in the rapid release of contents which may cause death, serious injury or property damage.**

The Kidde ECS Advanced Delivery System Switch-in-Gauge unit is factory installed on the cylinder valve, however the unit must be wired to a supervisory circuit and auxiliary power circuit of a Kidde Fire Systems control panel in order to obtain full functionality. Without an electrical connection the unit provides visual indication of the pressure within the container.

For the switch to function, allowing supervision of the container, the unit must be supplied power from the auxiliary power circuit via the red and black wires in the supplied tether. The non-polarity sensitive switched connection is made via the blue and brown wires to the supervised circuit of a control panel.

Connection into the control system wiring should be made in a suitable junction box using appropriate gauge wiring per NFPA 72: 1999.

## MAINTENANCE (MECHANICAL)

The unit and wiring tether should be checked visually during regular maintenance intervals for damage, corrosion or dial obscuration. No field calibration is possible or necessary.

## ORDERING INFORMATION

Part Number	Description
06-118328-001	Gauge Unit and Tether

## COMPATIBILITY

Series	For Use With
Kidde ECS Advanced Delivery with FM-200 <sup>®</sup> Agent	X
Kidde ECS Advanced Delivery with 3M <sup>™</sup> Novec <sup>™</sup> 1230 Fire Protection Fluid	X

## SPECIFICATIONS

### Factory Set Point:

**Low:** 1623 PSI (112 bar)  
**High:** 2062 PSI (142 bar)

### Contact Rating:

30 Vdc MAX  
 100mA MAX  
 65ohms (closed) MAX

### Wire Color Coding:

**Red:** Positive (24 Vdc nominal)  
**Black:** Negative  
**Brown/Blue:** Switch contacts

### Switch Operation:

NC, CLOSED under normal operating pressure  
 NO, OPEN when under/over-pressurized  
 NO, when power lost

### Power Requirements:

18 Vdc to 30 Vdc  
 Current draw in normal pressure state = 16 ma  
 Current draw in low pressure state = 7 ma

### Container Connection:

0.125-27 NPT (male)

### Wetted Materials:

Brass body, stainless steel working tube

### Lead Length:

36 in. (914 mm) nominal

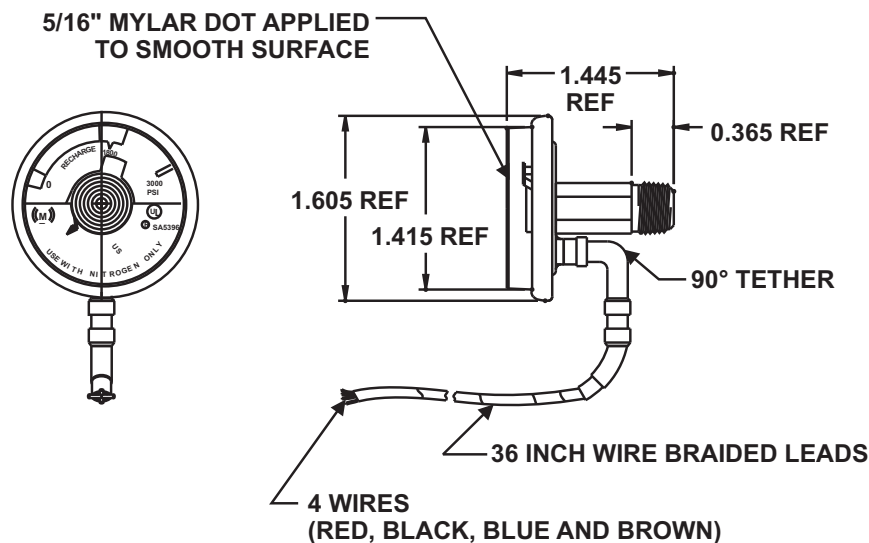

Figure 1. Switch-in-Gauge Dimensions

FM-200 is a registered trademark of E.I. du Pont de Nemours and Company. 3M and Novec are trademarks of 3M Company. Kidde is a registered trademark of Kidde-Fenwal Inc. All other trademarks are the property of their respective owners.

This literature is provided for informational purposes only. Kidde-Fenwal, Inc. assumes no responsibility for the product's suitability for a particular application. The product must be properly applied to work correctly. If you need more information on this product, or if you have a particular problem or question, contact Kidde-Fenwal, Inc.

